



Der Anhänger



NEU
MT SySTEMA®

**MOTORBIKE
TRAILER**



Insider schätzen die STEMA MOTORBIKE TRAILER.

Sie stehen für Sicherheit und Langlebigkeit, sind bequem zu Be- und Entladen und verfügen über eine perfekte Straßenlage. Die **neue MT SySTEMA Serie** ist darüber hinaus auch für anderes Transportgut geeignet. Mit wenigen Handgriffen sind Bordwände und Hochplane aufgesteckt. So schützen Sie Ihr Motorrad bei langen Fahrten oder meistern anderweitige Transporte.

Insiders appreciate STEMA MOTORBIKE TRAILERS.

They stand for safety and longevity, they provide comfortable loading and unloading and have a perfect road holding. Furthermore the **new MT SySTEMA series** is also suitable for other cargo. With a few grips side panels and high cover can be mounted. So you will protect your motorcycle in case of long journeys or you master another transportations.

MT SySTEMA®

NEU

*



Ungebremst oder Gebremst ?

Diese Entscheidung hängt von der Anzahl und dem Gewicht Ihrer Motorräder ab. Alle gebremsten STEMA-Anhänger ab 850 kg zul. Gesamtgewicht sind serienmäßig mit Stoßdämpfern ausgerüstet. Diese Anhänger können direkt bei der Zulassungsstelle für 100 km/h zugelassen werden. Es entfallen zusätzlich Kosten und Wege zum technischen Dienst (z.B. TÜV, DEKRA). Welche weiteren Faktoren in Deutschland eingehalten werden müssen, um mit einem Gespann tatsächlich 100 km/h fahren zu können, finden Sie unter www.stema.de



With or without overran brake ?

This decision is primarily depending of how many motorbikes have to be carried and on their weight. Every STEMA TRAILER with overran brake is already equipped with shock absorbers.

* For local regulation please contact our distributor

MOTORBIKE TRAILERS **SySTEMA**[®]

ungebremst / without overrun brake

tiefe Ladefläche und lange Auffahrschiene
für bequemes Be- und Entladen

low ramp height and long loading ramps for easy loading

ruhiges Fahrverhalten und robustes Fahrgestell

excellent road performance and robust chassis

im Boden versenkbare Verzurrösen und viele Verzurrpunkte auf den Standschienen

recessed lashing eyes and a bike transport rail with a lot of fixing points

stabile Radbügel für festen Stand der Motorräder

wheel holders for a solid stand of the motorbikes



Beispiel-Abb: STM O1 7.5-21-13.1



AUFFAHRSCHIENE CLEVER VERSTAUT

loading ramp cleverly stored



Typ model

zul. Gesamtgewicht (kg)	Nutzlast (kg)	Nutzabmessungen L x B (cm)	Außenabmessungen L x B x H (cm)	Felgendurchmesser (cm)	Standschienen	Art.-Nr.
maximum gross weight	payload	platform dimensions	external dimensions	wheels	bike transport rail	code

750 kg

STM O1 7.5-21-13.1	750	535	216 x 134	307 x 173 x 92,5	33,02 (13")	3	24710
STM O1 7.5-21-13.1 rot/red	750	535	216 x 134	307 x 173 x 92,5	33,02 (13")	3	24711
STM O1 7.5-21-15.1	750	525	216 x 159	307 x 198 x 92,5	33,02 (13")	3	24712
STM O1 7.5-21-15.1 rot/red	750	525	216 x 159	307 x 198 x 92,5	33,02 (13")	3	24713
STM O1 7.5-25-13.1	750	498	257 x 134	348 x 173 x 92,5	33,02 (13")	3	24714
STM O1 7.5-25-13.1 rot/red	750	498	257 x 134	348 x 173 x 92,5	33,02 (13")	3	24715
STM O1 7.5-25-15.1	750	485	257 x 159	348 x 198 x 92,5	33,02 (13")	3	24716
STM O1 7.5-25-15.1 rot/red	750	485	257 x 159	348 x 198 x 92,5	33,02 (13")	3	24717

MOTORBIKE TRAILERS SySTEMA®

gebremst / with overrun brake



km/h zulassungsfähig
permissible for 100 km/h



NEU

XXL Ladefläche bis 307 x 189 cm (L x B)

XXL platform up to 307 x 189 cm (L x W)

clever verstaut: die integrierte Auffahrschiene in jeder Standardausführung

clever stored: the integrated loading ramp

inklusive Verzurrösen, im Boden versenkbar
6 bis 8 Stück je nach Länge des Trailers

6 to 8 recessed lashing eyes
(depends on the length of the trailer)

MT SySTEMA Reling (optional)= viele zusätzliche Verzurrpunkte

MT SySTEMA reling (option)= many fixing points

TRAILER-Ausführung nach EG Norm
mit Unterfahrschutz-Bügel an beiden Seiten

TRAILER-according to the new EU-standard
underrun protection on both sides



sportliches Design:

auf Wunsch in **Rot**

sportive design:

red color on request

Bemaßung Auffahrschiene (cm)
Dimensions of loading ramp (cm)

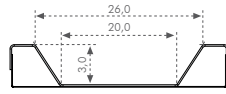

Bemaßung Radhalterbügel (cm)
Dimensions of wheel holder (cm)

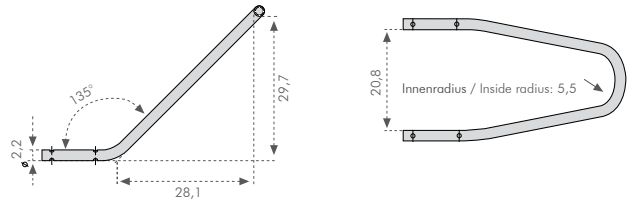

Typ model

zul. Gesamtgewicht (kg)	Nutzlast (kg)	Nutzabmessungen L x B (cm)	Außenabmessungen L x B x H (cm)	Felgendurchmesser (cm)	Stand-schienen	Bremse / Stützrad / Stoßdämpfer	Art.-Nr.
maximum gross weight	payload	platform dimensions	external dimensions	wheels	bike transport rail	brake/ jockey wheel/shock absorber	code

850 kg

STM 02 8.5-21-13-1	850	576	216 x 134	328 x 177 x 92,5	33,02 (13")	3	✓/✓/✓	24720
STM 02 8.5-21-13-1 rot/red	850	576	216 x 134	328 x 177 x 92,5	33,02 (13")	3	✓/✓/✓	24721
STM 02 8.5-21-15.1	850	566	216 x 159	328 x 202 x 92,5	33,02 (13")	3	✓/✓/✓	24722
STM 02 8.5-21-15.1 rot/red	850	566	216 x 159	328 x 202 x 92,5	33,02 (13")	3	✓/✓/✓	24723
STM 02 8.5-25-13-1	850	539	257 x 134	369 x 177 x 92,5	33,02 (13")	3	✓/✓/✓	24724
STM 02 8.5-25-13-1 rot/red	850	539	257 x 134	369 x 177 x 92,5	33,02 (13")	3	✓/✓/✓	24725
STM 02 8.5-25-15.1	850	526	257 x 159	369 x 202 x 92,5	33,02 (13")	3	✓/✓/✓	24726
STM 02 8.5-25-15.1 rot/red	850	526	257 x 159	369 x 202 x 92,5	33,02 (13")	3	✓/✓/✓	24727

1000 kg

STM 02 10-21-13-1	1000	726	216 x 134	328 x 177 x 92,5	33,02 (13")	3	✓/✓/✓	24730
STM 02 10-21-13-1 rot/red	1000	726	216 x 134	328 x 177 x 92,5	33,02 (13")	3	✓/✓/✓	24731
STM 02 10-21-15.1	1000	716	216 x 159	328 x 202 x 92,5	33,02 (13")	3	✓/✓/✓	24732
STM 02 10-21-15.1 rot/red	1000	716	216 x 159	328 x 202 x 92,5	33,02 (13")	3	✓/✓/✓	24733
STM 02 10-25-13-1	1000	689	257 x 134	369 x 177 x 92,5	33,02 (13")	3	✓/✓/✓	24734
STM 02 10-25-13-1 rot/red	1000	689	257 x 134	369 x 177 x 92,5	33,02 (13")	3	✓/✓/✓	24735
STM 02 10-25-15.1	1000	676	257 x 159	369 x 202 x 92,5	33,02 (13")	3	✓/✓/✓	24736
STM 02 10-25-15.1 rot/red	1000	676	257 x 159	369 x 202 x 92,5	33,02 (13")	3	✓/✓/✓	24737

1300 kg

STM 02 13-21-15.1	1300	1016	216 x 159	328 x 202 x 92,5	33,02 (13")	3	✓/✓/✓	24742
STM 02 13-21-15.1 rot/red	1300	1016	216 x 159	328 x 202 x 92,5	33,02 (13")	3	✓/✓/✓	24743
STM 02 13-25-15.1	1300	976	257 x 159	369 x 202 x 92,5	33,02 (13")	3	✓/✓/✓	24744
STM 02 13-25-15.1 rot/red	1300	976	257 x 159	369 x 202 x 92,5	33,02 (13")	3	✓/✓/✓	24745
STM 02 13-25-18-1	1300	956	257 x 189	413 x 232 x 92,5	33,02 (13")	3	✓/✓/✓	24746
STM 02 13-25-18-1 rot/red	1300	956	257 x 189	413 x 232 x 92,5	33,02 (13")	3	✓/✓/✓	24747
* SHM 02 13-25-18.1	1300	956	257 x 189	413 x 232 x 92,5	25,40 (10")	3	✓/✓/✓	24760
* SHM 02 13-25-18.1 rot/red	1300	956	257 x 189	413 x 232 x 92,5	25,40 (10")	3	✓/✓/✓	24761

1500 kg

STM 02 15-25-18-1	1500	1176	257 x 189	413 x 232 x 92,5	33,02 (13")	3	✓/✓/✓	24748
STM 02 15-25-18-1 rot/red	1500	1176	257 x 189	413 x 232 x 92,5	33,02 (13")	3	✓/✓/✓	24749
STM 02 15-30-18.1	1500	1220	307 x 189	463 x 226 x 92,5	33,02 (13")	3	✓/✓/✓	24750
STM 02 15-30-18.1 rot/red	1500	1220	307 x 189	463 x 226 x 92,5	33,02 (13")	3	✓/✓/✓	24751
* SHM 02 15-25-18.1	1500	1176	257 x 189	413 x 232 x 92,5	25,40 (10")	3	✓/✓/✓	24762
* SHM 02 15-25-18.1 rot/red	1500	1176	257 x 189	413 x 232 x 92,5	25,40 (10")	3	✓/✓/✓	24763
* SHM 02 15-30-18.1	1500	1205	307 x 189	463 x 226 x 92,5	25,40 (10")	3	✓/✓/✓	24766
* SHM 02 15-30-18.1 rot/red	1500	1205	307 x 189	463 x 226 x 92,5	25,40 (10")	3	✓/✓/✓	24767

* Hochlader / platform trailer

MOTORBIKE TRAILERS SySTEMA®

Zubehör & Aufsätze / accessories for platforms



STEMA MOTORBIKE TRAILER sind langlebige und zuverlässige Begleiter. Die neue Modellreihe MT-SySTEMA ist besonders flexibel für diverse Einsatzbereiche. Funktionelle Aufsätze, wie Bordwand und Hochplane machen Ihren Anhänger zum Allrounder.

STEMA MOTORBIKE TRAILER is your best friend for a long life and the new MT SySTEMA can grow along with you. With the wide range of accessories your trailer provides various and flexible applications at any time.

Typ model

	zusätzliche Auffahrschiene inkl. Gleitschiene (1 Stück) Motorrad additional loading ramp (1 pcs.) bike	zusätzliche Auffahrrampe inkl. Gleitschiene (1 Stück) Quad additional loading ramp (1 pcs.) quad	Stützrad jockey wheel	Abstellstützen loading stands	Ersatzradhalter spare wheel holder	Ersatzrad spare wheel
750 kg						
STM 01 7.5-21-13.1	ZT00648	ZT00448	ZT00406	ZT00445	ZT00649	ET4505597
STM 01 7.5-21-15.1	ZT00648	ZT00448	ZT00406	ZT00445	ZT00649	ET4505597
STM 01 7.5-25-13.1	ZT00648	ZT00448	ZT00406	ZT00445	ZT00649	ET4505597
STM 01 7.5-25-15.1	ZT00648	ZT00448	ZT00406	ZT00445	ZT00649	ET4505597
850 kg						
STM 02 8.5-21-13.1	ZT00648	ZT00448	✓	ZT00445	ZT00649	ET4505597
STM 02 8.5-21-15.1	ZT00648	ZT00448	✓	ZT00445	ZT00649	ET4505597
STM 02 8.5-25-13.1	ZT00648	ZT00448	✓	ZT00445	ZT00649	ET4505597
STM 02 8.5-25-15.1	ZT00648	ZT00448	✓	ZT00445	ZT00649	ET4505597
1000 kg						
STM 02 10-21-13.1	ZT00648	ZT00448	✓	ZT00445	ZT00649	ET4505609
STM 02 10-21-15.1	ZT00648	ZT00448	✓	ZT00445	ZT00649	ET4505609
STM 02 10-25-13.1	ZT00648	ZT00448	✓	ZT00445	ZT00649	ET4505609
STM 02 10-25-15.1	ZT00648	ZT00448	✓	ZT00445	ZT00649	ET4505609
1300 kg						
STM 02 13-21-15.1	ZT00648	ZT00448	✓	ZT00445	ZT00649	ET4505626
STM 02 13-25-15.1	ZT00648	ZT00448	✓	ZT00445	ZT00649	ET4505626
STM 02 13-25-18.1	ZT00648	ZT00448	✓	ZT00445	ZT00649	ET4505634
* SHM 02 13-25-18.1	ZT00648	ZT00448	✓	ZT00445	ZT00649	ET4505637
1500 kg						
STM 02 15-25-18.1	ZT00648	ZT00448	✓	ZT00445	ZT00649	ET4505634
STM 02 15-30-18.1	ZT00648	ZT00448	✓	ZT00445	ZT00649	ET4505634
* SHM 02 15-25-18.1	ZT00648	ZT00448	✓	ZT00445	ZT00649	ET4505637
* SHM 02 15-30-18.1	ZT00648	ZT00448	✓	ZT00445	ZT00649	ET4505637

* Hochlader / platform trailer

Bei Ersatzradnachbestellung bitte unbedingt die Fahrzeugidentnummer Ihres MOTORBIKE TRAILERS angeben! / For order of spare wheel please give us the chassis number of your MOTORBIKE TRAILER.

NEU

Zusätzliche Funktionen für MT SySTEMA TRAILER
accessories for MT SySTEMA TRAILERS



Bordwand (Vorderwand fest)	Bordwand (Vorderwand klappbar)	Hochspiegel & Hochplane Höhe 150 cm	Seitenreling (1 Paar) Höhe 10 cm	Frontreling (1 Stück) Höhe 10 cm
side panel (front panel fix)	side panel (front panel falled down)	high frame & high cover height 150 cm	side railing (2 pcs.) height 10 cm	front railing (1 pcs.) height 10 cm

Adapterset Höhe 25 cm	Hochspiegel Höhe 150 cm	Hochplane mit Haken Höhe 185 cm
adapter set height 25 cm	high frame height 150 cm	high cover with hooks height 185 cm

ZT00460	ZT00488	ZT00318	ZT00558	ZT00533
ZT00589	-	ZT00319	ZT00558	ZT00534
ZT00461	ZT00437	ZT00320	ZT00559	ZT00533
ZT00468	ZT00498	ZT00321	ZT00559	ZT00534

ZT00539	16631	Z4508559.1
ZT00539	16632	Z4508560.1
ZT00539	16627	Z4508561.1
ZT00539	16628	Z4508558.1

ZT00460	ZT00488	ZT00318	ZT00558	ZT00533
ZT00589	-	ZT00319	ZT00558	ZT00534
ZT00461	ZT00437	ZT00320	ZT00559	ZT00533
ZT00468	ZT00498	ZT00321	ZT00559	ZT00534

ZT00539	16631	Z4508559.1
ZT00539	16632	Z4508560.1
ZT00539	16627	Z4508561.1
ZT00539	16628	Z4508558.1

ZT00460	ZT00488	ZT00318	ZT00558	ZT00533
ZT00589	-	ZT00319	ZT00558	ZT00534
ZT00461	ZT00437	ZT00320	ZT00559	ZT00533
ZT00468	ZT00498	ZT00321	ZT00559	ZT00534

ZT00539	16631	Z4508559.1
ZT00539	16632	Z4508560.1
ZT00539	16627	Z4508561.1
ZT00539	16628	Z4508558.1

ZT00589	-	ZT00319	ZT00558	ZT00534
ZT00468	ZT00498	ZT00321	ZT00559	ZT00534
ZT00590	-	ZT00363	ZT00559	ZT00535
ZT00590	** ZT00591	ZT00363	ZT00559	ZT00535

ZT00539	16632	Z4508560.1
ZT00539	16628	Z4508558.1
ZT00539	16629	Z4508570.1
ZT00539	16629	Z4508570.1

ZT00590	-	ZT00363	ZT00559	ZT00535
ZT00455	** ZT00569	ZT00325	ZT00560	ZT00535
ZT00590	** ZT00591	ZT00363	ZT00559	ZT00535
-	** ZT00569	ZT00325	ZT00560	ZT00535

ZT00539	16629	Z4508570.1
ZT00539	16621	Z4508571.1
ZT00539	16629	Z4508570.1
ZT00539	16621	Z4508571.1

** allseitig klappbar / all side falled down

MOTORBIKE TRAILERS CLASSIC

ungebremst / without overrun brake

Bemaßung Auffahrschiene (cm)
Dimensions of loading ramp (cm)

MT 750/850
Länge Auffahrschiene / length loading rail: 194

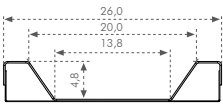

Beispiel-Abb: MT 750 BS2

geeignet für ein bis zwei Motorrädern.
to carry comfortably from one up to two motorbikes.

MT 750 BS1

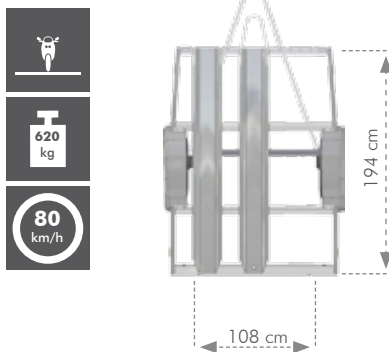

MT 750 BS2

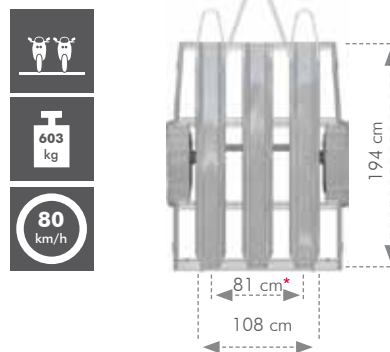

MT 750 BS3

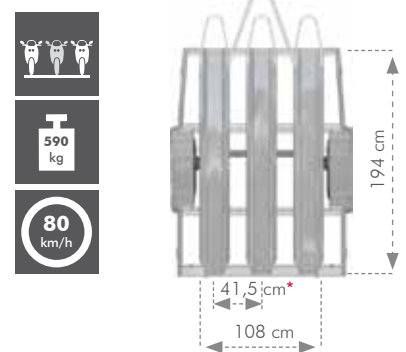

Typ model



Typ model	zul. Gesamtgewicht (kg) maximum gross weight	Nutzlast (kg) payload	Nutzabmessungen L x B (cm) platform dimensions	Außenabmessungen L x B (cm) external dimensions	Felgendurchmesser (cm) wheels	Standsschienen bike transport rail	Bremse / Stützrad / Stoßdämpfer brake/ jockey wheel/shock absorber	Art.-Nr. zum Teil länderspezifisch code
MT 750 BS1	750	620	194 x 108	292 x 152	33,02 (13")	1	-/-/-	22691
MT 750 BS2	750	603	194 x 108	292 x 152	33,02 (13")	2	-/-/-	20894
MT 750 BS3	750	590	194 x 108	292 x 152	33,02 (13")	3	-/-/-	20951
MT 850 BS2	850	680	194 x 108	286 x 152	33,02 (13")	2	✓/✓/✓	21042
MT 850 BS3	850	680	194 x 108	286 x 152	33,02 (13")	3	✓/✓/✓	22540

gebremst / with overrun brake

Die MT CLASSICS sind jahrelang erprobte Modelle. Mit der wartungsfreien Gummifederachse, Einzelradaufhängung und erweiterter Spurenbreite laufen sie optimal und ruhig auf der Straße. Zur serienmäßigen Ausstattung der MOTORBIKE TRAILER CLASSIC gehören eine Auffahrschiene und vier (MT...BS1) bzw. acht Klauenhaken (MT...BS2/3). Bei gebremsten Anhängern sind die Auflaufbremse und das Stützrad Standard.

MT CLASSICS are your best friends. The strong and maintenance free rubber spring axle with independent wheel suspension and extended wheelbase is the guarantee for an excellent road performance. Standard equipment includes a loading ramp for all MT Classics and four (MT...BS1) or eight (MT...BS2/3) claw hooks. Braked trailers also include overrun brake and jockey wheel.



  **100 km/h zulassungsfähig**
permissible for 100 km/h

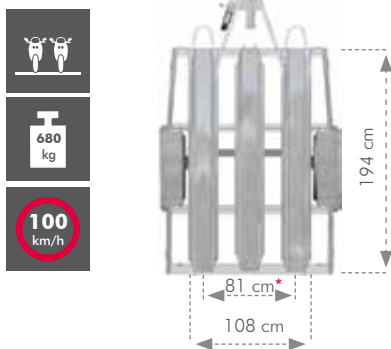

MT 850 BS2

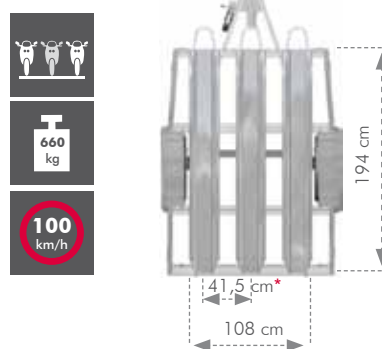

MT 850 BS3



LEGENDE / CAPTION

-  Abmessung
Dimensions
-  Abstand Standschienen (von Mitte zu Mitte)
Distance of transportation rails
-  1, 2 oder 3 Motorräder
1, 2 oder 3 motorbikes
-  Nutzlast
payload
680 kg
-  Standardzulassung
Permissible for 80 km/h
-  Für 100 km/h zulassungsfähig
Permissible for 100 km/h

Ersatzrad	Ersatzradhalter	Abstellstützen	Auffahrschiene	Standschiene inkl. Vorderradhaltebügel	Stützrad	Unterlegkeile (VPE 2 Stück)
spare wheel	spare wheel holder	loading stands	loading ramp	bike transport rail complete	jockey wheel	chock block
ET4505597	ZT00651	ZT00652	ZT00653	ZT00413	ZT00406	ZT00452
ET4505597	ZT00651	ZT00652	ZT00653	ZT00413	ZT00406	ZT00452
ET4505597	-	ZT00652	ZT00653	ZT00413	ZT00406	ZT00452
ET4505597	ZT00651	ZT00652	ZT00653	ZT00413	inkl. / incl.	inkl. / incl.
ET4505597	-	ZT00652	ZT00653	ZT00413	inkl. / incl.	inkl. / incl.

UNI TRAILER CLASSIC



EIN Anhänger = VIELE Anwendungen! Der UNI ist multifunktional und transportiert Ihr Motorrad, Quad oder den Rasentraktor. Das passende Zubehör finden Sie unter www.stema.de.

The UNI Trailer is an all purpose all-rounder. Whether you intend to move your bike or quad or you take your lawn tractor to a friend the UNI Trailer does it all. For accessories please visit: www.stema.de

ungebremst
without overrun brake



gebremst
with overrun brake



UNI 752

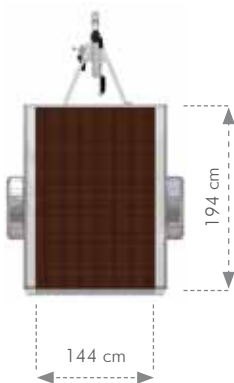

UNI 852

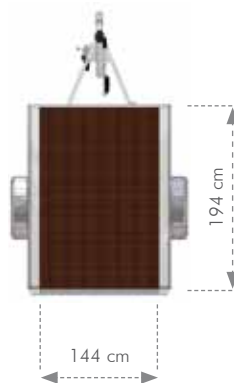
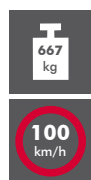

Typ model	zul. Gesamtgewicht (kg) maximum gross weight	Nutzlast (kg) payload	Nutzabmessungen L x B (cm) platform dimensions	Außenabmessungen L x B (cm) external dimensions	Felgendurchmesser (cm) wheels	Bremse / Stützrad / Stoßdämpfer brake / jockey wheel / shock absorber	Art.-Nr. code	Standsschiene inkl. Vorderradhalterbügel bike transport rail complete	Auffahrschienen (1 Stück) loading ramp (1 pcs.)
UNI 752	750	592	198 x 144	300 x 185	33,02 (13")	-/-/-	22229	ZT00413	ZT00654
UNI 852	850	667	198 x 144	300 x 185	33,02 (13")	✓/✓/✓	22231	ZT00413	ZT00654

RADHALTER WIPPE / CRADLE-STYLE WHEEL CHOCK

Das Geheimnis der Radhalter Wippe ...

... steckt in der optimalen Ausnutzung der Schwerkraft Ihres Motorrads. Sie schieben das Motorrad über den Kippmechanismus. Durch das eigene Gewicht wird das Motorrad fest verankert. Die Wippe sichert einen festen Stand auf nahezu jedem Untergrund. Mit Hilfe von vier stabilen Schrauben läßt sich die Wippe auf fast jedem STEMA Anhängern montieren. Zum Transport ist das Motorrad zusätzlich zu sichern.



The secret of cradle-style wheel chocks...

... is optimal use of gravity. Just push or ride your motorcycle over the cradle mechanism and your motorcycle's own weight will cause the cradle to lock the entering wheel in place. The wheel chock securely supports your motorcycle in an upright position on any ground or floor. The chocks can be fitted to any STEMA trailer by means of 4 stable bolts. For transport please use additional fastenings bells to fix your motorbike.

Typ model	Außenabmessungen L x B x H (cm) external dimensions	geeignet für used for	Art.-Nr. code
Radhalter-Wippe fix wheel holder compensator fixed	55 x 21 x 29	15" - 19" Räder / Radbreite 100 - 130 mm 15" - 19" wheels / 100 - 130 mm wide	ZT00658
Radhalter-Wippe variabel wheel holder compensator variable	70 x 27,5 x 31	13" - 21" Räder / Radbreite 90 - 200 mm 13" - 21" wheels / 90 - 200 mm wide	ZT00659

PRAKTISCHES ZUBEHÖR USEFUL ACCESSORIES



Motorrad Lenkerspanngurt
motorbike fastening belts

Art.-Nr.: ZT00655



Spanngurt
fastening belts

Art.-Nr.: ZT00656



Diebstahlsicherung
theft protection

Art.-Nr.: ET3404211



Deichselbox (verschießbar)
drawbar box (lockable)

Art.-Nr.: ZT00657

mehr Zubehör unter:
more accessories

www.stema.de



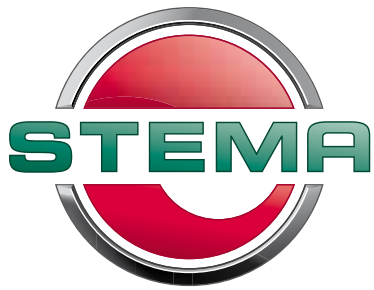

Der Anhänger



**Mehr als 1 Million
PKW-Anhänger!**

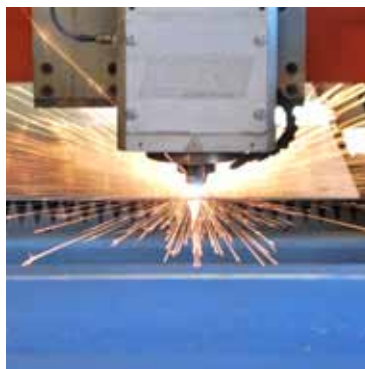

Ihr / Your STEMA Partner



STEMA Metalleichtbau GmbH

Rieser Straße 50
01558 Großenhain

www.stema.de
info@stema.de

STEMA Servicetelefon +49 (0) 900 - 13 09 40 01

Diese Telefonnummer ist gebührenpflichtig und aus dem deutschen Festnetz für 0,96 €/Min. erreichbar und ggf. abweichenden Preisen aus dem Mobilfunk.

MADE IN GERMANY